

KOBAR - Coarse Screen

Product
Information

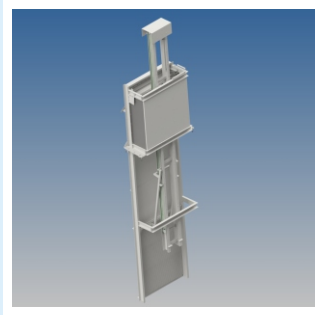

Hubert KOBAR Bar Screen - used for small water flows

The Hubert Kobar chain operated raked coarse screen is provided with a linear moving rake. This screen system is applied for pre-cleaning of relative small water flows in channels with low water levels and is rarely used in water intake systems (sometimes in an inlet for low-scale drinking water production in a fresh water environment). Applications are more often found in the influent of wastewater treatment.

Design & Construction

The Hubert Kobar chain-operated coarse screen construction is based on channels with a low water level and is especially designed for vertical or slightly inclined installation. The screen is designed for front-raked operation.

This bar screen is manufactured as a pre-assembled unit for direct installation into position on site. The simple rigid & robust design ensures reliable operation with maximum cleaning of the incoming flow.

Features & Benefits

- No moving parts below water level
- Maintenance free
- One (1) cleaning cycle over complete screen width
- Pre-assembled, skid mounted and easy to install

Standard Dimensions & Materials

- Width up to 4 m
- Pit depth (height) up to 12 m
- Bar space 6/20 mm
- Installation angle 70/90°
- Materials: (coated) carbon steel, stainless steel, (super) Duplex



Company Profile

Hubert, founded in 1880, has almost 150 years experience in design & engineering, in-house manufacturing, installation & service of equipment for water purification and water intake applications. Our engineered products and technical expertise have enabled Hubert to become a major player on the global markets for water treatment solutions. We focus on high quality equipment with a long service life.

Over the years we gained an extensive number of satisfied customers & project references all over the world. Our machinery is a crucial part of every production facility and usually continuous in operation. Our equipment has to operate efficiently and reliably in extreme (weather) conditions. Hubert's installed base comprise many thousands of installations that have recently commissioned or that have been in operation for many years.

Below you can find more information about our divisional structure. We will be happy to hear about your project!

Our Divisions

Water Intake Systems

Hubert is market leader in water intake screening systems, used for mechanically clean water extracted from the sea, rivers or lakes. These systems can be found in power stations, petrochemical plants & refineries, desalination plants, drinking water & irrigation plants and industrial production plants requiring a huge demand of process water.

We supply complete complete 'screening trains' including all additional equipment, like controls and cathodic protection. We design, engineering and manufacture our equipment in-house.

You will find our projects in both new construction (EPC) projects and renovation & optimization of existing water intakes.

Waste Water Treatment Machinery

Hubert supplies waste water treatment machinery & (sub)installations applied in municipal and industrial waste water treatment plants. Our installations are of high quality and offer a long service life.

Clients range from water boards and authorities in the public sector, to multinationals in many industries.

Service & After Sales

Keeping your machinery operational. This is the daily work of our Service & After Sales division which proves its importance by keeping Hubert installations operational anywhere in the world. Founded in 1880, the large amount of projects that Hubert has carried out over the years has resulted in a huge installed base of equipment. Many of these are still in operation! We supply parts but also provide optimization and renovation of your existing equipment.

High-Spec Steel Assemblies

Hubert has been supplying both components and assembled parts to the offshore industry and other applications within the shipping and dredging industry for many years. Complex machined welding constructions, (sub) assemblies and complete products are part of our program.

For this market we work according to customer (mechanical) specs. Our scope includes parts in single pieces, series as well as assembled products.

