

SWCC - MARAFIQ / Saudi Archirodon Yanbu II Power and Desalination Plant

Project
Information

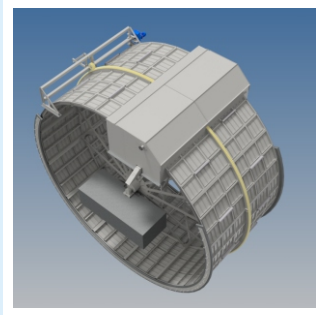

Project Introduction

Hubert was awarded the contract for delivery of the marine package or seawater intake filtration system. Hubert was responsible for ensuring that the specification was met for all deliveries in subcontracting.

Hubert Supply

This project involved the construction of the complete seawater intake filtration system, consisting of 4 channels or intake 'trains'. The seawater intake filtration system is designed to remove completely sea grass / weed, debris, plastic bags, wood chip, mollusk, jelly fish etc.

The 4 delivered Hubert drum screens have a diameter of 13 m and a width of 6,6 and have a capacity of 110.000 m³/h. Hubert Bar Screens were used to keep out large parts. Bar screens will be periodic cleaned by an automatic raking system, placed on a monorail construction.

Hubert stop logs permit rapid and secure closure of very large inlet channels and pump chambers, to make periodic inspection and maintenance of screening systems and pupms possible.

Hubert was also responsible for supply of the spray water system , the cathodic protection facility and all project-related E&I work.

In 2015 Hubert supplied to the Yanbu III project 10 drum screens with diameter 11 m x width 6,2 m in s.s. 316, capacity 123.800 m³/h

Key Figures

Location	Saudi Arabia
Hubert Products	drum screens, stop logs, bar screens & monorail raking system
Materials	Duplex
Year	2013



Company Profile

Hubert, founded in 1880, has almost 150 years experience in design & engineering, in-house manufacturing, installation & service of equipment for water purification and water intake applications. Our engineered products and technical expertise have enabled Hubert to become a major player on the global markets for water treatment solutions. We focus on high quality equipment with a long service life.

Over the years we gained an extensive number of satisfied customers & project references all over the world. Our machinery is a crucial part of every production facility and usually continuous in operation. Our equipment has to operate efficiently and reliably in extreme (weather) conditions. Hubert's installed base comprise many thousands of installations that have recently commissioned or that have been in operation for many years.

Below you can find more information about our divisional structure. We will be happy to hear about your project!

Our Divisions

Water Intake Systems

Hubert is market leader in water intake screening systems, used for mechanically clean water extracted from the sea, rivers or lakes. These systems can be found in power stations, petrochemical plants & refineries, desalination plants, drinking water & irrigation plants and industrial production plants requiring a huge demand of process water.

We supply complete complete 'screening trains' including all additional equipment, like controls and cathodic protection. We design, engineering and manufacture our equipment in-house.

You will find our projects in both new construction (EPC) projects and renovation & optimization of existing water intakes.

Waste Water Treatment Machinery

Hubert supplies waste water treatment machinery & (sub)installations applied in municipal and industrial waste water treatment plants. Our installations are of high quality and offer a long service life.

Clients range from water boards and authorities in the public sector, to multinationals in many industries.

Service & After Sales

Keeping your machinery operational. This is the daily work of our Service & After Sales division which proves its importance by keeping Hubert installations operational anywhere in the world. Founded in 1880, the large amount of projects that Hubert has carried out over the years has resulted in a huge installed base of equipment. Many of these are still in operation! We supply parts but also provide optimization and renovation of your existing equipment.

High-Spec Steel Assemblies

Hubert has been supplying both components and assembled parts to the offshore industry and other applications within the shipping and dredging industry for many years. Complex machined welding constructions, (sub) assemblies and complete products are part of our program.

For this market we work according to customer (mechanical) specs. Our scope includes parts in single pieces, series as well as assembled products.

